



De Hart & Vaatgroep



umcg



# Waarom wel of geen erfelijkheidsonderzoek?

Drs. Karin Nieuwhof, cardiogenetisch consulent

Rina Keupink, cardiogenetisch consulent

Jo Jacobs, maatschappelijk werker



- Uit de praktijk
- Erfelijkheidsonderzoek
  - Wat kunnen we onderzoeken?
  - Waarom wel of geen erfelijkheidsonderzoek?
  - Wat kunnen de gevolgen zijn?
- Een ervaringsdeskundige aan het woord
- Vragen



De Hart & Vaatgroep



umcg



# Uit de praktijk...





De Hart & Vaatgroep



umcg



STICHTING  
GENETISCHE HARTSPIERZIEKTE  
**PLN**

# Uit de praktijk...

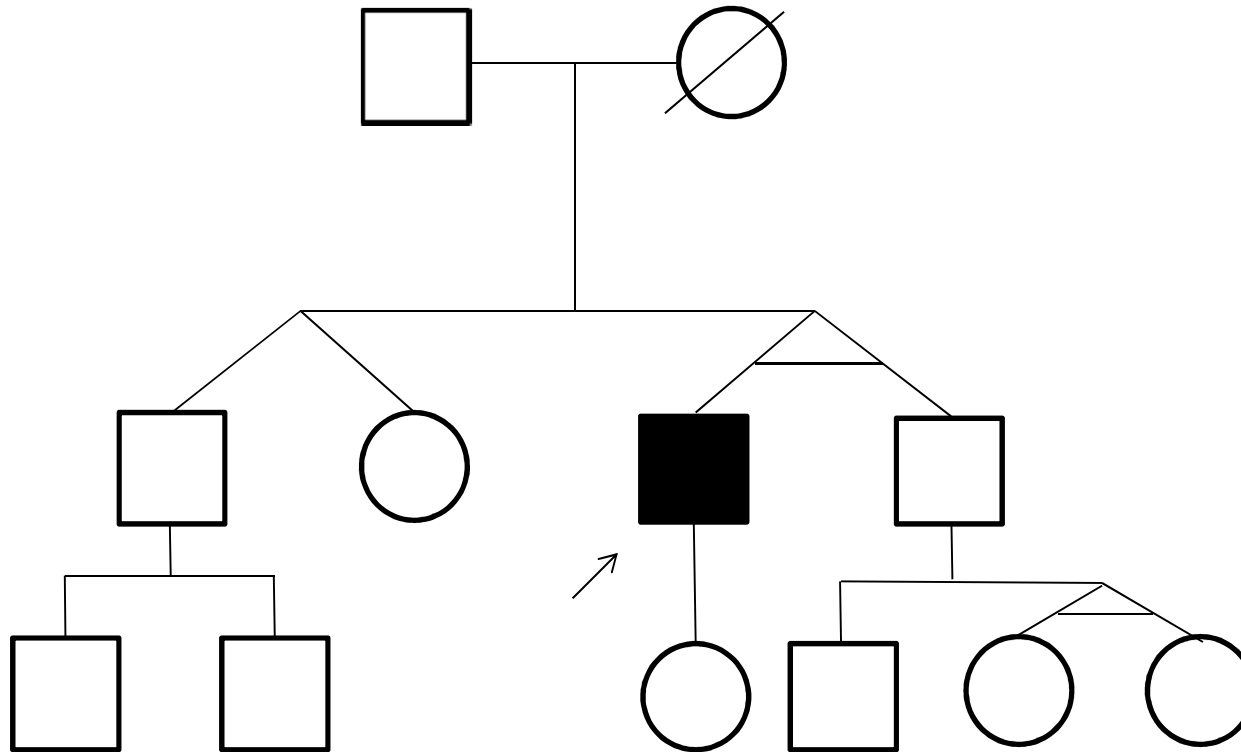





De Hart & Vaatgroep



umcg



# Erfelijkheidsonderzoek

- Patiënt

- Genenpanel
- 1-3 maanden

**Gevolgen voor patiënt**

- Familieleden

- Specifiek mutatie-onderzoek (2-4 weken)
- Cardiologisch onderzoek (i.p. dezelfde dag)
- Combi-onderzoek (dezelfde dag + 2-4 weken)

**Gevolgen voor familieleden**





De Hart & Vaatgroep



umcg



# Erfelijkheidsonderzoek

- Duidelijkheid
- Diagnose
- Mogelijkheden voor familieleden
- Behandeling

**Gevolgen voor patiënt**

Maar ook:

- Onduidelijkheid
- Schuldgevoel
- Angst





De Hart & Vaatgroep



umcg



STICHTING  
GENETISCHE HARTSPIERZIEKTE  
**PLN**

# Uit de praktijk...

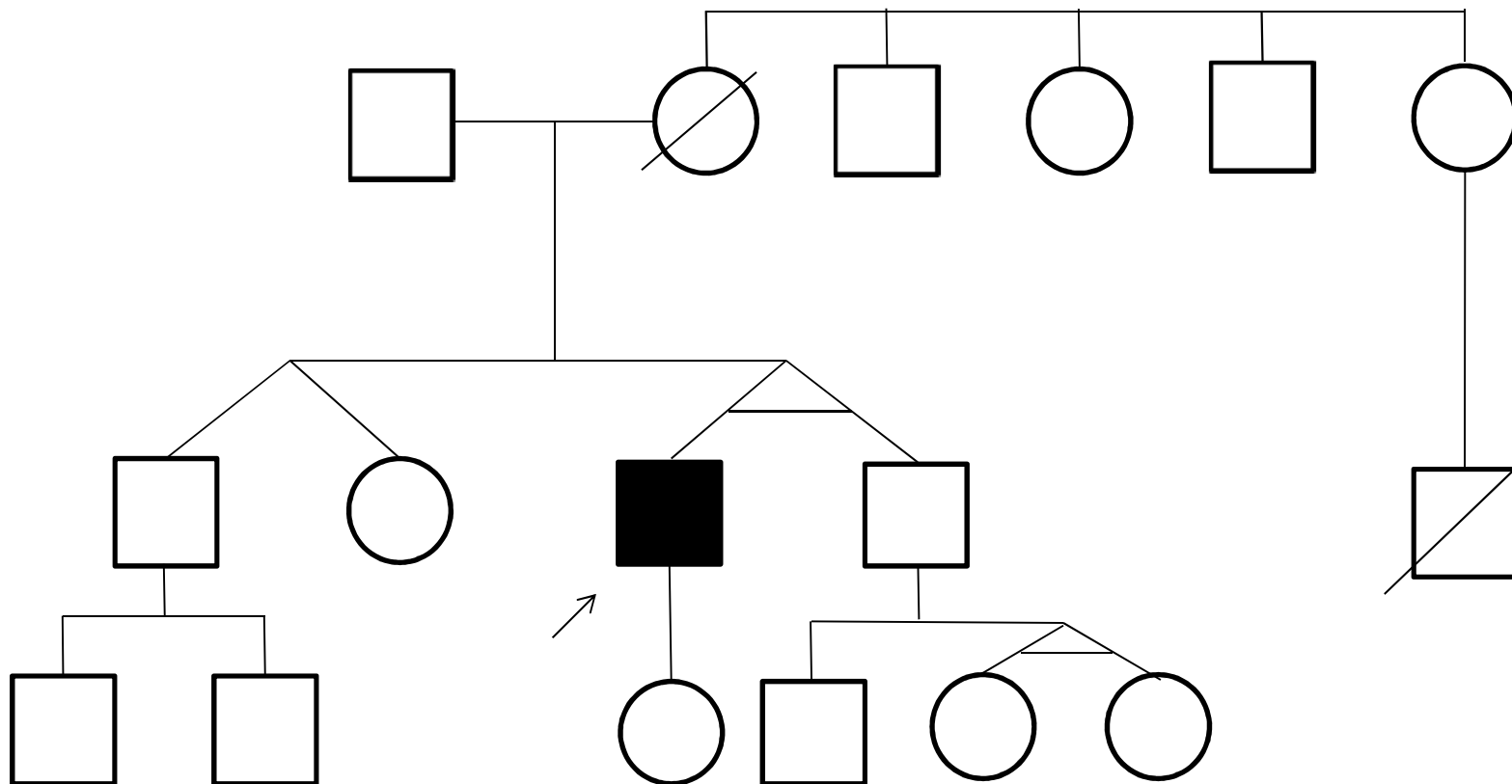





De Hart & Vaatgroep



umcg



# Uit de praktijk....

- DNA-uitslag: erfelijke oorzaak aangetoond.





De Hart & Vaatgroep



umcg



# Erfelijkheidsonderzoek

- Geruststelling
- Duidelijkheid/ zekerheid
- Tijdige opsporing > erger beperken

**Gevolgen voor familieleden**

Maar ook:

- Onrust indien drager
- Sport mogelijk?
- Gevolgen voor werk?
- Verzekeringen
- Zwangerschap/ kinderwens







De Hart & Vaatgroep



umcg



STICHTING  
GENETISCHE HARTSPIERZIEKTE  
**PLN**

# Uit de praktijk...

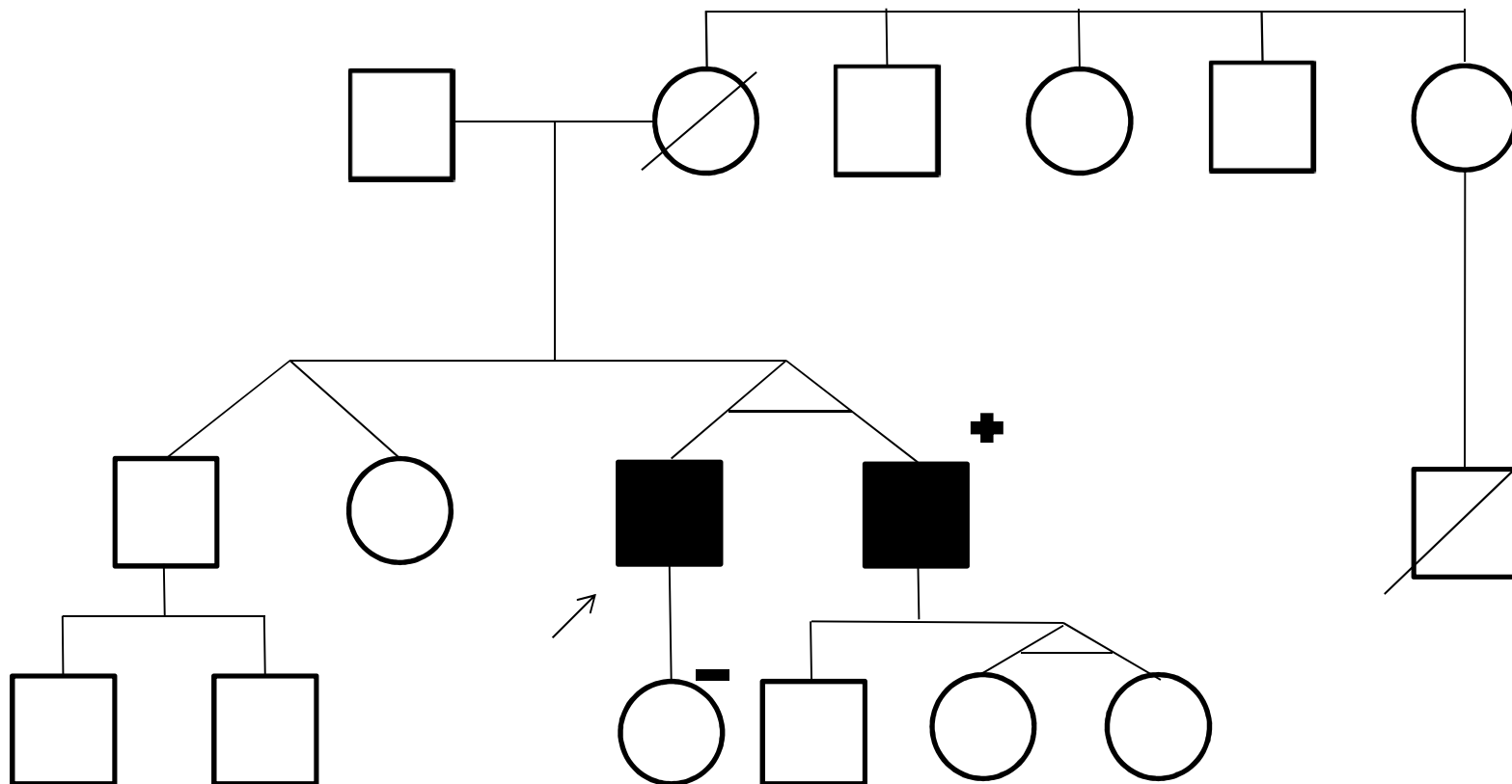



De Hart & Vaatgroep



umcg



STICHTING  
GENETISCHE HARTSPIERZIEKTE  
**PLN**

# Uit de praktijk...

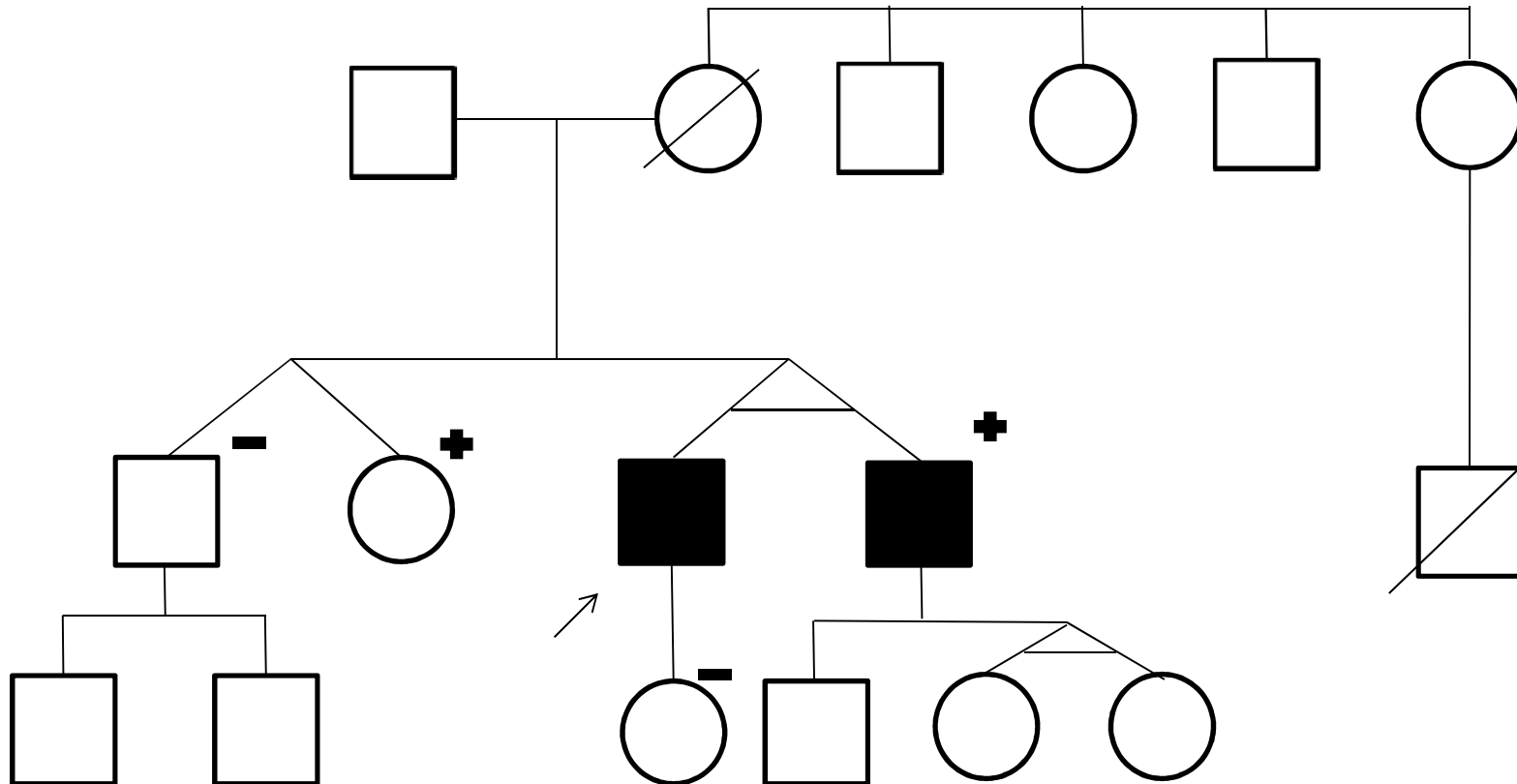



De Hart & Vaatgroep



umcg



STICHTING  
GENETISCHE HARTSPIERZIEKTE  
**PLN**

# Uit de praktijk...

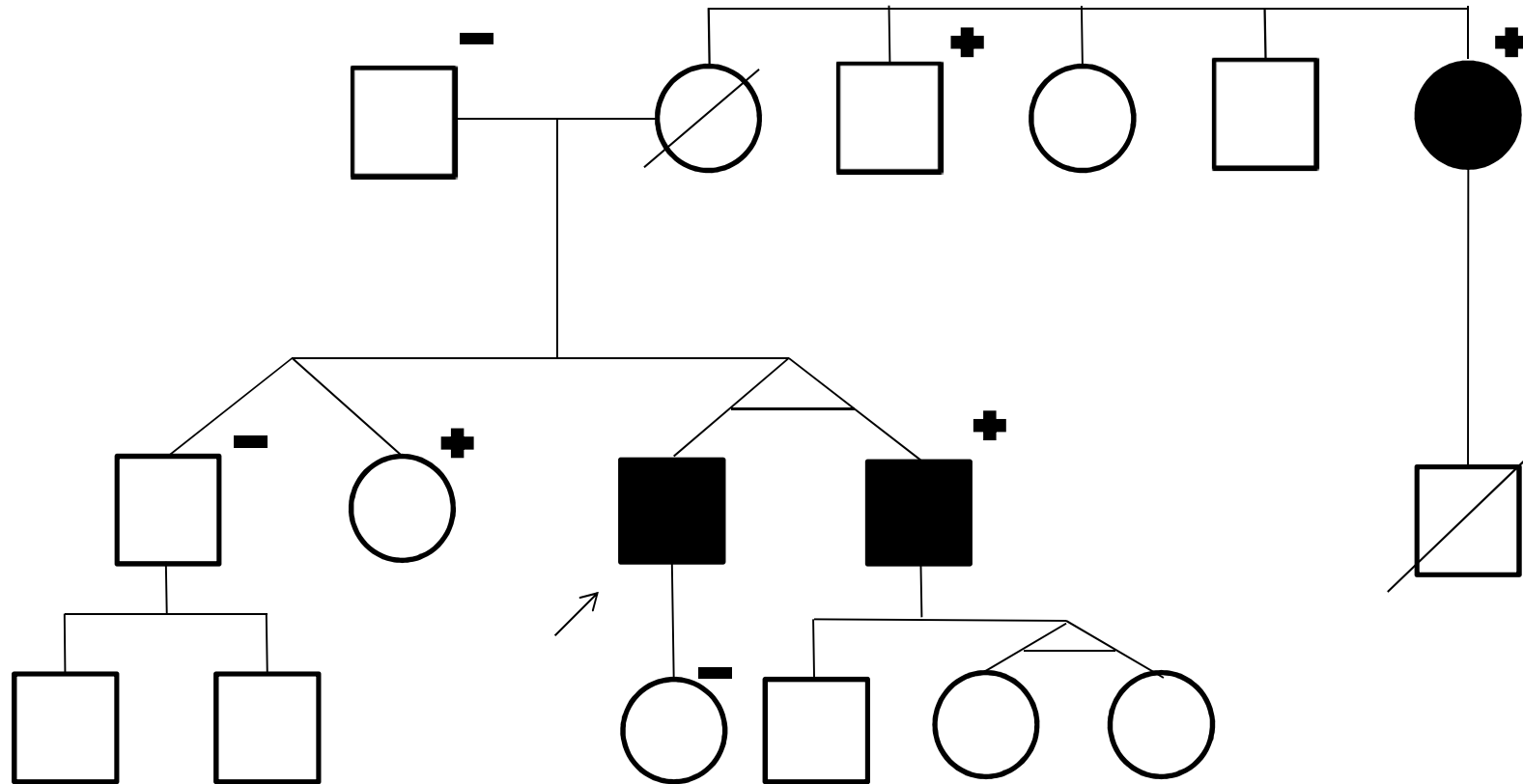



De Hart & Vaatgroep



umcg



STICHTING  
GENETISCHE HARTSPIERZIEKTE

PLN

# Een ervaringsdeskundige



Expertisecentrum cardiogenetica UMCG





De Hart & Vaatgroep



umcg



STICHTING  
GENETISCHE HARTSPIERZIEKTE  
**PLN**

# DNA-onderzoek bij familieleden

- Beleid bij familieleden die zelf ook al duidelijk verschijnselen hebben:
  - Altijd met DNA-onderzoek bevestigen
  - Tevens uitgebreid DNA-onderzoek (panel)
- Redenen:
  - Soms grote verrassingen
  - Misschien een extra verandering in het DNA die bijdraagt: van belang voor familieleden (kinderen).
- Ons advies: altijd bevestigen met DNA-onderzoek

Zekerheid!





De Hart & Vaatgroep



umcg



STICHTING  
GENETISCHE HARTSPIERZIEKTE  
**PLN**

# Cardiologisch onderzoek

- Welke cardiologisch screening is belangrijk?
  - ECG
  - Echocardiogram





De Hart & Vaatgroep



umcg



STICHTING  
GENETISCHE HARTSPIERZIEKTE  
**PLN**

# Bedankt voor uw aandacht!

Bij behoefte aan verdere informatie over erfelijke hartaandoeningen:  
laat het gerust weten!

Er is veel te vertellen en er is veel en uiteenlopende kennis.

De ontwikkelingen gaan snel, technieken en inzichten nemen toe.

## Vragen?

Karin Nieuwhof, cardiogenetisch consulent, Klinische Genetica UMCG



Expertisecentrum cardiogenetica UMCG